

Electric pump

EL25A/B

PUMP SPECIFICATIONS	Mod. A	Mod. B
Capacity [m ³ /h - (USGPM)]	100 - (440)	140 - (616)
Head [m - (ft)]	21 - (69)	17 - (56)
Impeller diameter [mm - (in)]/type	380 - (15)/2 blades closed	
Flanged bore size [DN.../PN... - (in)]	DN100/PN10 - (4)	DN150/PN10 - (6)
Cross section diameter [mm - (in)]	35 - (1.4)	
Weight (without cable) [kg - (lbs)]	680 - (1500)	695 - (1530)

ELECTRIC MOTOR	
Power [kW-HP]	18-25
Voltage [V]/Current [A]	460/30.8
Phases/Poles/Frequency [Hz]	3/6/60
Speed [RPM]	1180
Insulation class	H
Power cable 20m (IEC 60245- 4)	H07RN-F 4G16

MATERIALS	
Casing	Spheroidal cast iron EN-GJS-500-7 (EN 1563)
Motor housing	Cast iron EN-GJL-250 (EN 1561)
Wear parts	High chrome EN-GJN-HV600 (XCr18) (EN 12513)
Main shaft	High tensile steel 39NiCrMo3 (AISI 9840)

SEALS / LUBRICANT	
Motor side seals	2 lipseals (BUNA)
Impeller side seals	5 lip seals (3 BUNA + 2 PTFE) + 1 V-RING (TPU)
Oil type	ISO 320

DIMENSIONS [mm - (in)]							
H	W	D	F	H1	A	B	C
1360	795	670	535	905	335	350	145
(54.4)	(31.8)	(26.8)	(21.4)	(36.2)	(13.4)	(14)	(5.8)

PERFORMANCE CURVES

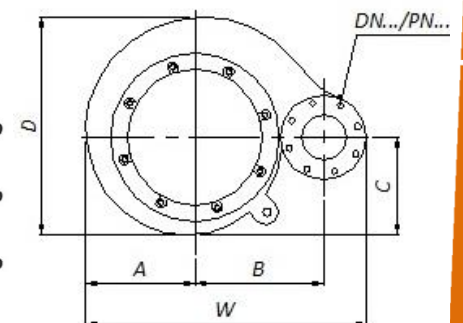
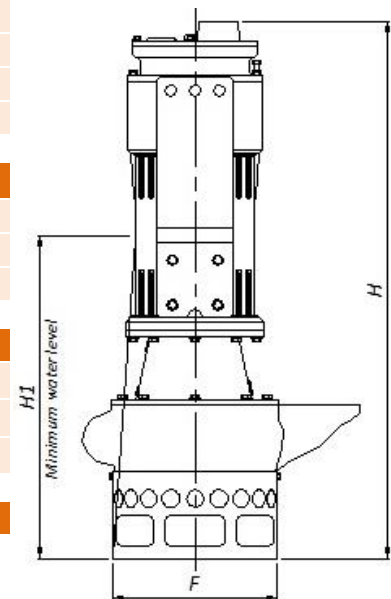
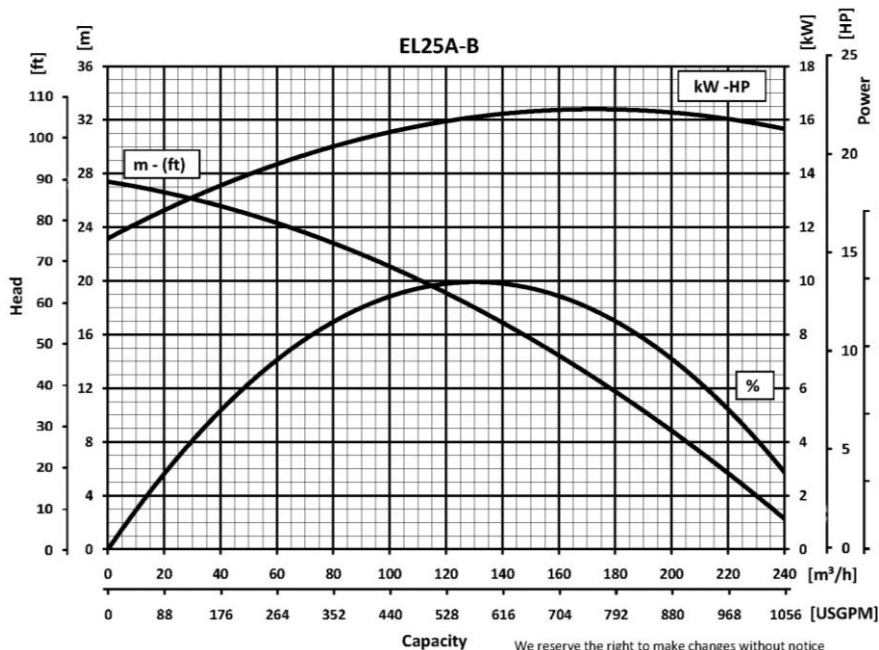

EL25A-B

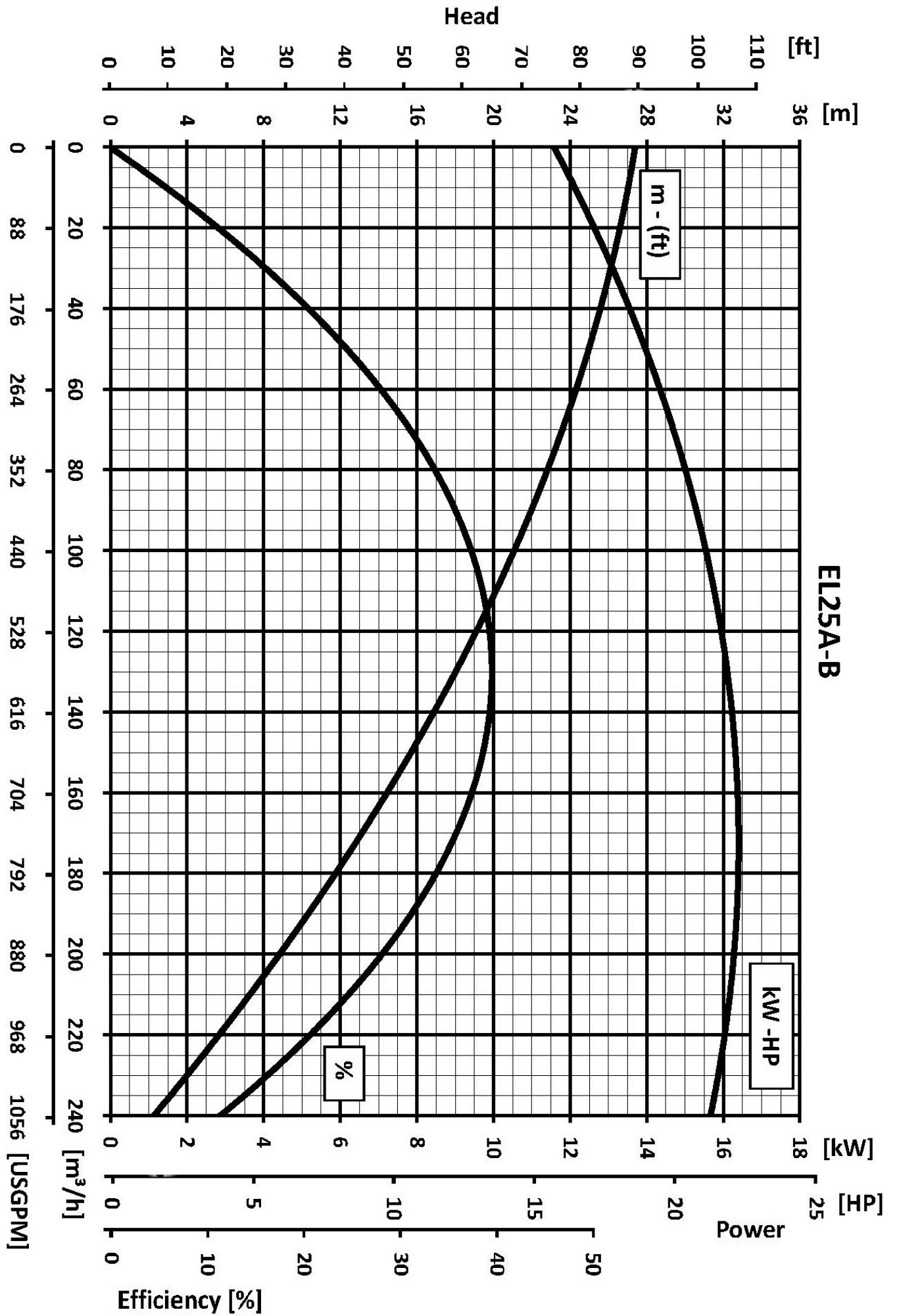

Capacity We reserve the right to make changes without notice