

Electric pump

EL400

PUMP SPECIFICATIONS

Max Capacity [m ³ /h - USGPM]	1400 - 6200
Max Head [m - ft]	62 - 200
Impeller diameter [mm - in]/type	650 - 26 /2 blades opened
Flanged bore size [DN/PN - in]	DN250/PN10 - 10
Solid handling [mm - in]	120 - 5
Weight [kg - lb]	6300 - 13890

ELECTRIC MOTOR

Power [kW - HP]	325-440
Voltage [V]/Current [A]	460 / 510
Phases/Poles/Frequency [Hz]	3 / 10 / 60
Speed [RPM]	720
Insulation class	H
Power cable 20 m (IEC 60245-4)	2 x H07RN-F 4G95

MATERIALS

Casing	Spheroidal cast iron EN-GJS500-7 (EN1563)
Motor housing	Cast iron EN-GJL-250 (EN 1561)
Wear parts	High chrome EN-GJN-HV600 (XCr18) (EN12513)
Main shaft	High tensile steel 39NiCroMo3 (AISI 9840)

SEALS / LUBRICANT

Motor side seals	3 lip seals (2 BUNA + 1 PTFE)
Impeller side seals	5 lip seals (3 BUNA + 2PTFE) + 1 V-ring (TPU)
Oil type	ISO 32

DIMENSIONS [in]

H	W	D	F	H1	A	B	C
140	140	63	40	100	25	30	18

PERFORMANCE CURVES

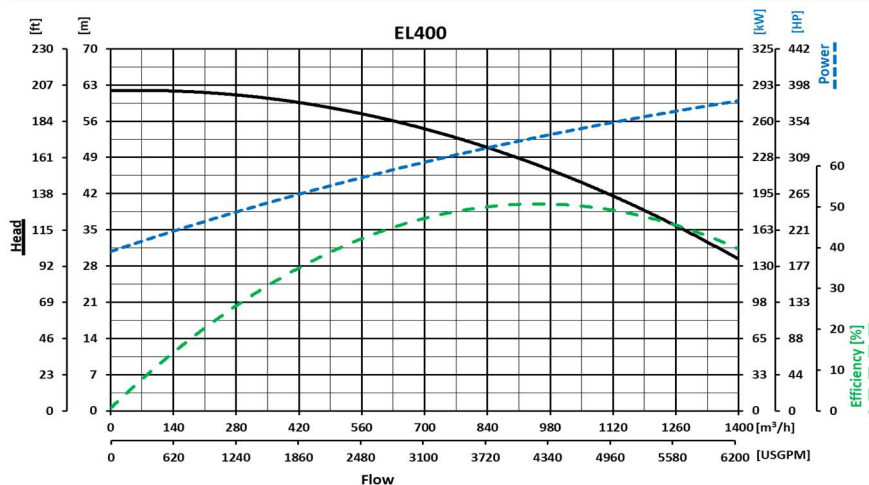

We reserve the right to make changes without notice

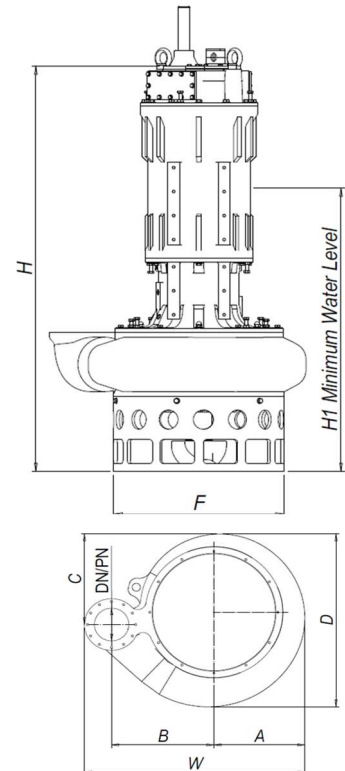
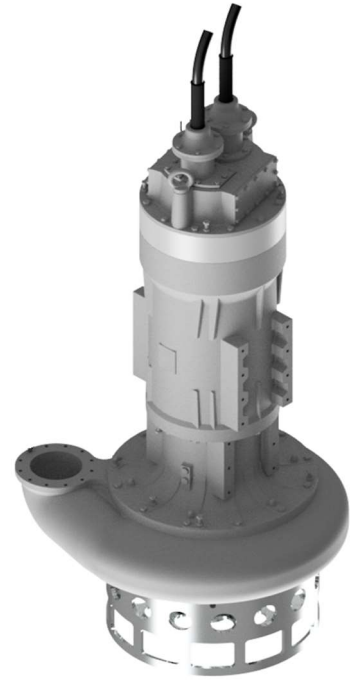

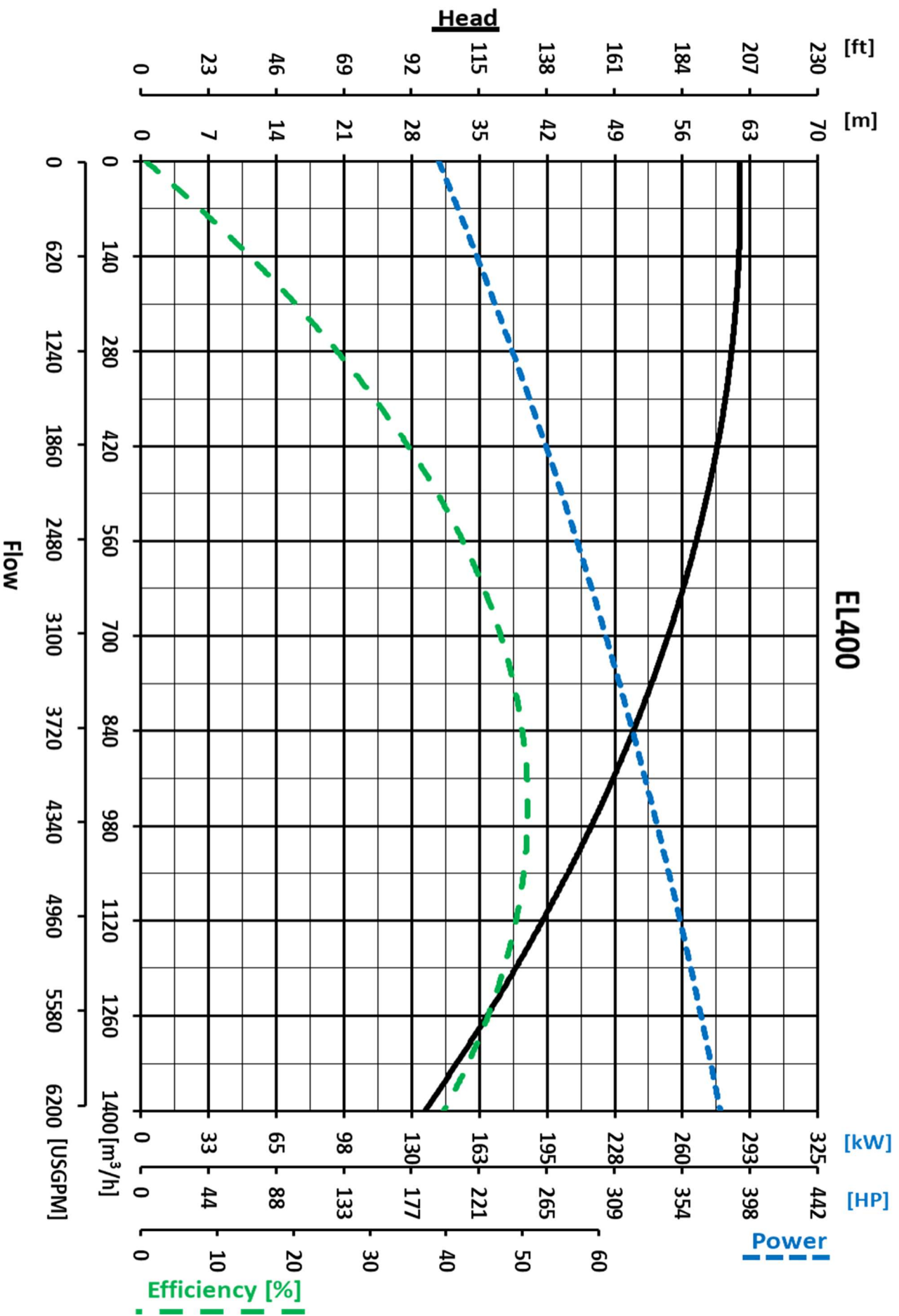

We reserve the right to make changes without notice